

# 群落物种共存的分子机制探讨

胡新生

华南农业大学林学与风景园林学院

2020年6月18日



华南农业大学  
**林学与风景园林学院**  
College of Forestry and Landscape Architecture

# Outline

---

## I. 应用基因序列分析的进化生物学基础

- 群落维持的基本机制
- 中性理论
- 自然选择
- 谱系分选
- $Ka/Ks$
- 有害突变基因固定

## II. 分析数据

- 物种共存研究对象
- PAML分析
- 案例

## III. 群落物种共存选择压预测

- 迁移影响
- 交配系统影响

# 群落维持的基本机制: 基本进化动力

群体遗传多样性维持

Vs.

群落物种多样性维持

漂变( $N_e$ )  
迁移( $m, \sigma^2$ )  
突变( $\mu$ )  
选择( $s$ )

交配系统( $\alpha$ )  
重组( $r$ )



群落漂变( $J$ )  
扩散( $\sigma^2$ )  
物种形成( $\nu$ )  
选择( $s$ )

问题:

- (1) 是群落物种多样性维持决定种群遗传多样性，还是反过来？
- (2) 物种多样性与单物种遗传多样性的关系 (species-gene diversity correlation, SGDC) 可以用DNA序列数据验证吗？

# 群落维持的基本机制: 中性理论

Table 1. A comparison between population genetics and neutral macroecology.

Items	Population genetics	Macroecology
Operational units	Population	Metacommunity
subdivision	Subpopulations	Local communities
focal unit	Gene	Species
observed data	Allele frequency	Species abundance
Neutral definition	Alleles are selectively neutral, selection coefficient $\approx 0$ , or $< 1/2N_e$	Individuals have equal vital rates
Driving forces	Genetic drift ( $1/2N_e$ )	Ecological drift ( $1/J_M$ or $1/J_L$ )
	Mutation	Speciation
Spatial structure	Gene flow among subpopulations	Dispersal among local communities
	Population genetic structure	Species distribution and abundance variation among local communities
model	Island model	Island biogeography
	Stepping stone model	
	Isolation by distance	Dispersal limitation
	Mainland -island	Metacommunity-local community
	Cline pattern (speciation phases)	
measurement	$1 - F_{is}$	$\alpha$ -diversity
	$F_{st}$	$\beta$ -diversity
	Spatial autocorrelation	Species-area power law
Parameters	$\theta = 4N_e v$	$\theta = 2J_M v$ or $2J_L v$
	Average number of migrants ( $N_e m$ )	Average number of migrants ( $J_L m$ )
	Effective population size ( $N_e$ )	Effective community size ( $J_M$ or $J_L$ )
	Distribution of allele frequency	Distribution of species abundance
	Fixed (extinct) probability of an allele	Fixed (extinct) probability of a species
	Times to equilibrium or extinction for a mutant	Times to equilibrium or extinction of a species
Assembly rules	Genetic drift/mutation	Ecological drift/speciation
	Genetic drift/migration	Ecological drift/dispersal
	Genetic drift/migration/mutation	Ecological drift/dispersal/speciation

# 群落维持的基本机制: 自然选择

## 群体遗传多样性维持

Vs.

## 群落物种多样性维持

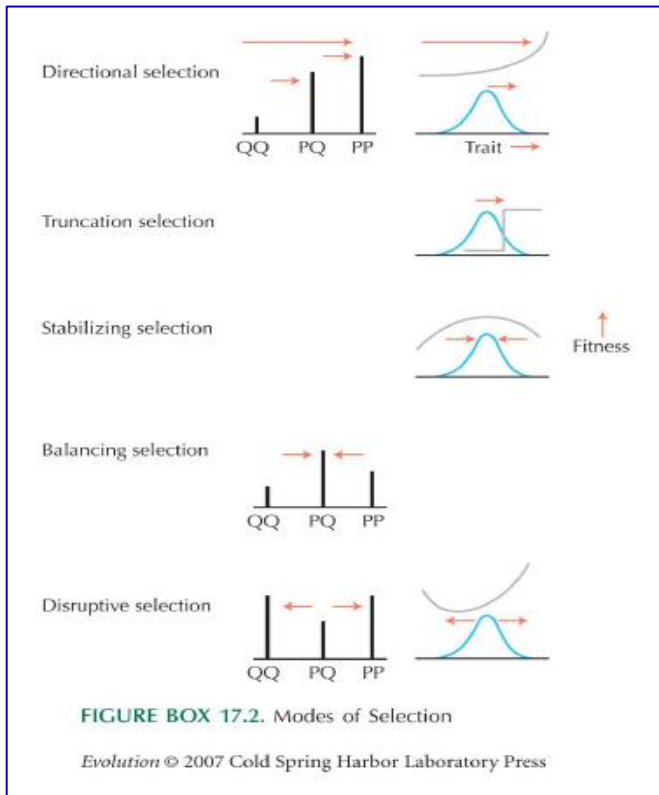

Frequency-dependent selection  
(positive, negative)

Stochastic selection

生态位优先占领模型

对数正态分布

正/负密度制约模型

随机生态位模型

...

问题:

谱系分选(lineage sorting)与生态位关系? 怎样影响物种共存呢(相似相容或竞争)?

# 谱系分选与物种共存: 群落物种组成



From Evolution 2007 Cold Spring Harbor Laboratory Press (Figure 2.43)

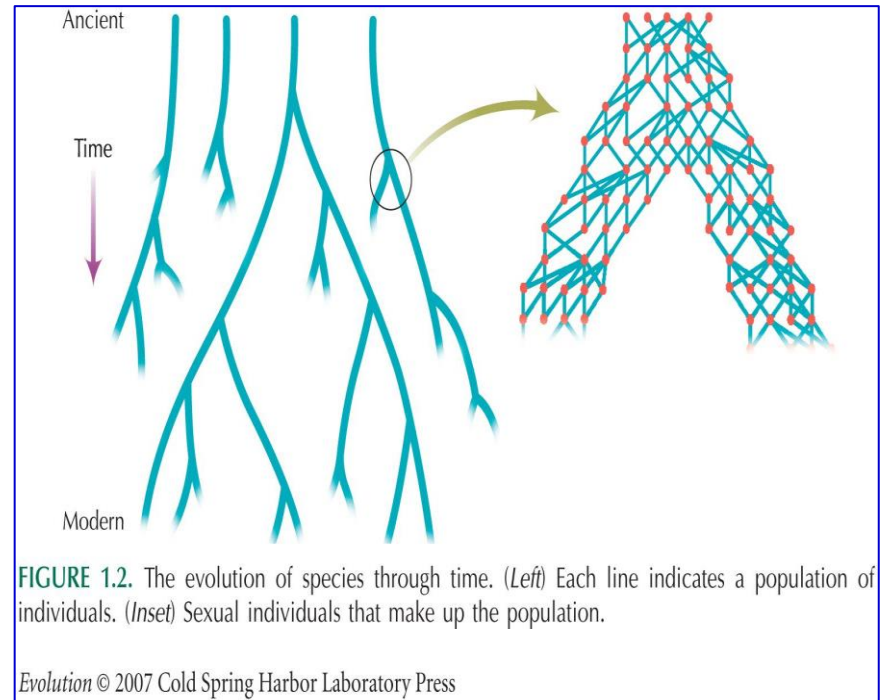

## 从Darwin视角看群落:

以群体为单位进化，分裂成不同物种，有的消失，有的在自然选择下适应生存下来(分支树)，在相同或不同的生态位等分布，时间上往回看，最后溯祖到共同祖先：一个群落就是一个系统进化分支树

## 谱系分选过程：三阶段

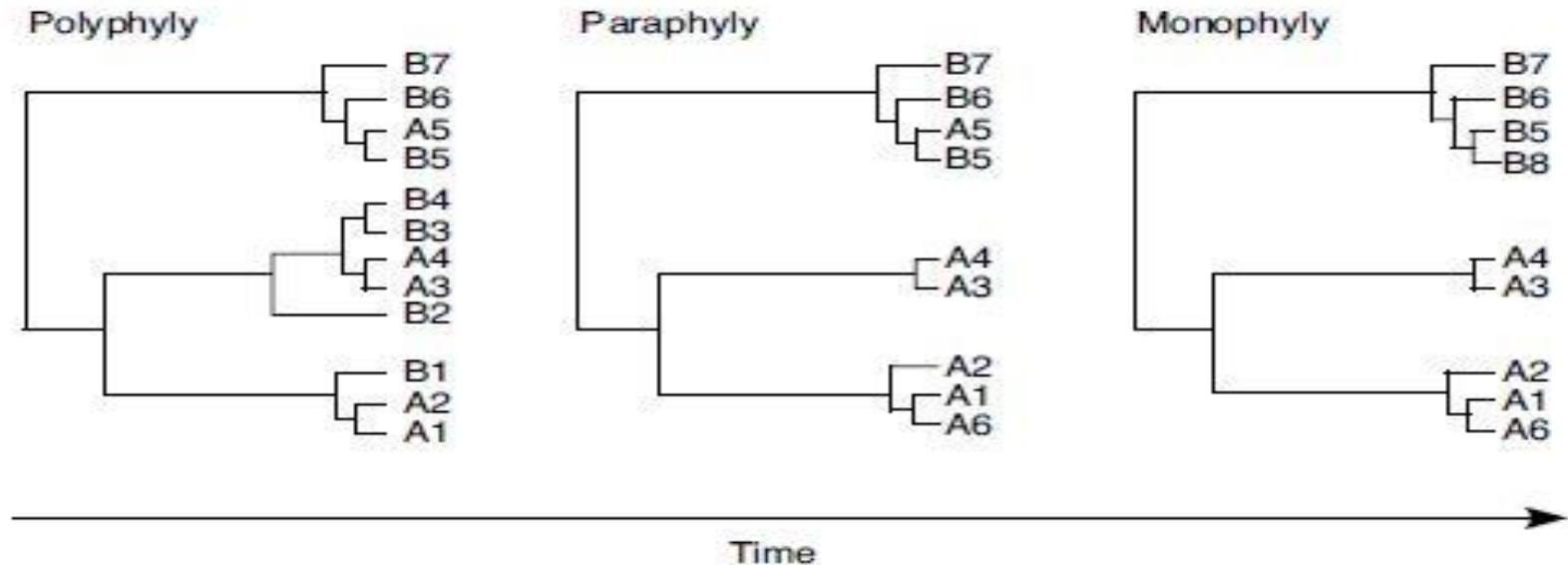

**Figure 6.15** The progression from polyphyly to monophyly in two recently separated, reproductively isolated populations that are undergoing lineage sorting. A and B refer to the populations in which the different alleles were found. After the populations are first separated they are polyphyletic, because some of the alleles in population A are most closely related to some of the alleles in population B, and vice versa. Over time, alleles are both gained (following mutation) and lost (following selection or drift), leading to an intermediate stage in which population A is paraphyletic with respect to population B. Eventually the populations become monophyletic, which occurs when all A alleles are genealogically most similar to one another, and all B alleles are genealogically most similar to one another.

中性基因与适应性基因分选进程不一致，形态分类与DNA序列分类有可能不一致

# 谱系分选过程：概率变化

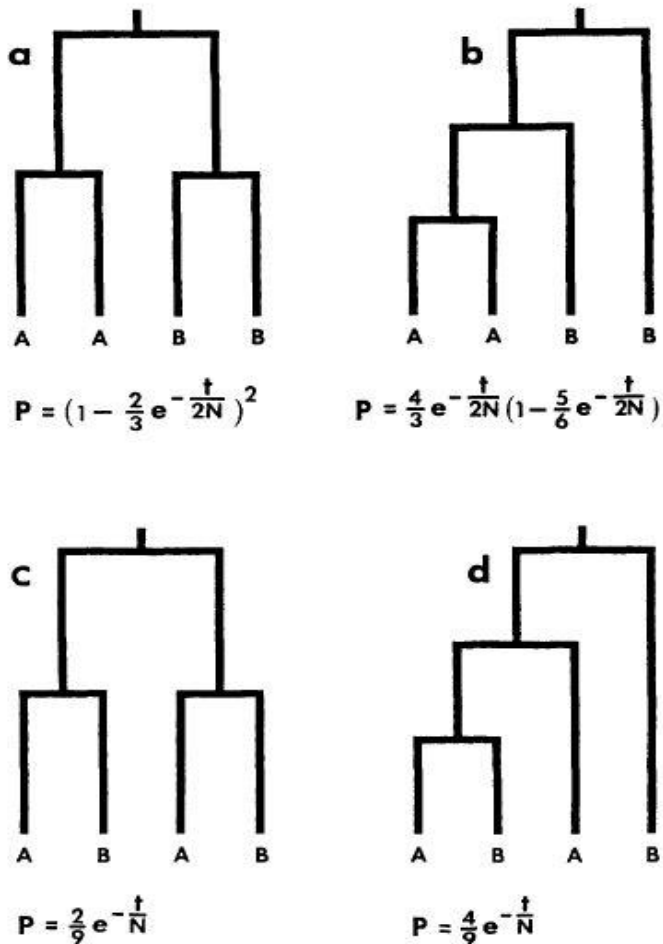

FIGURE 5.—Expected evolutionary relationships among four nucleons sampled from two populations, e.g., populations A and B, which diverged  $t$  generations ago. It is assumed that two nucleons are sampled from population A and the other two nucleons are sampled from population B.  $N$  is the effective population size in each population.

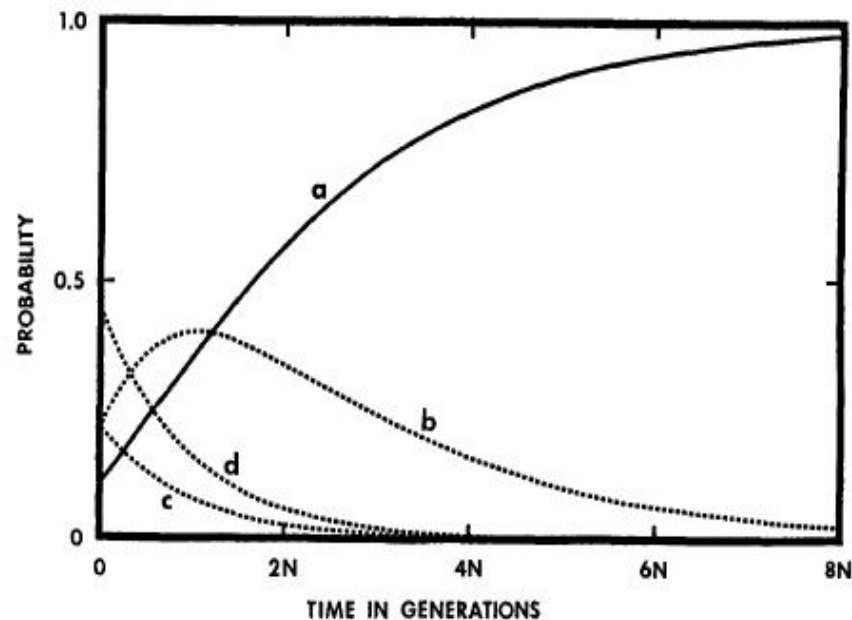

FIGURE 6.—Relationship between the probability of obtaining a certain type of evolutionary relationship in Figure 5 and the divergence time of two populations.

随着时间推移，单系发生的概率趋于1



## $K_a/K_s(dN/dS)$ 比率: 物种间(分化种群)

$$\frac{K_a}{K_s} = \frac{2Ns}{1 - e^{-2Ns}}$$

$\frac{K_a}{K_s} > 1$  when  $s > 0$  (正选择, 或Darwin 选择);

= 1 when  $s = 0$  (中性);

< 1 when  $s < 0$  (负选择, 或纯化选择)

$$\frac{\partial K_a/K_s}{\partial N} = \frac{2s(1 - e^{-2Ns} - 2Nse^{-2Ns})}{(1 - e^{-2Ns})^2}$$

> 0 (正选择), 种群越大, 种间出现正选择的比率越多

< 0 (负选择), 种群越小, 种间出现负选择的比率越多

## $K_a/K_s(dN/dS)$ 比率: 单个种群

$$\frac{K_a}{K_s} = \frac{D(\gamma, \theta)}{D(0, \theta)}$$

式中:  $D(\gamma, \theta) = \int_0^1 2x(1-x)\Phi(x|\gamma, \theta)dx$

$$\Phi(x|\gamma, \theta) = Cx^{\theta-1}(1-x)^{\theta-1}e^{2\gamma x} \int_x^1 \xi^{-\theta}(1-\xi)^{-\theta}e^{-2\gamma\xi}d\xi$$

$$\theta = 2N\mu, \gamma = Ns$$

$$\frac{\partial K_a/K_s}{\partial N}$$

在一定的选择范围内有类似的变化趋势

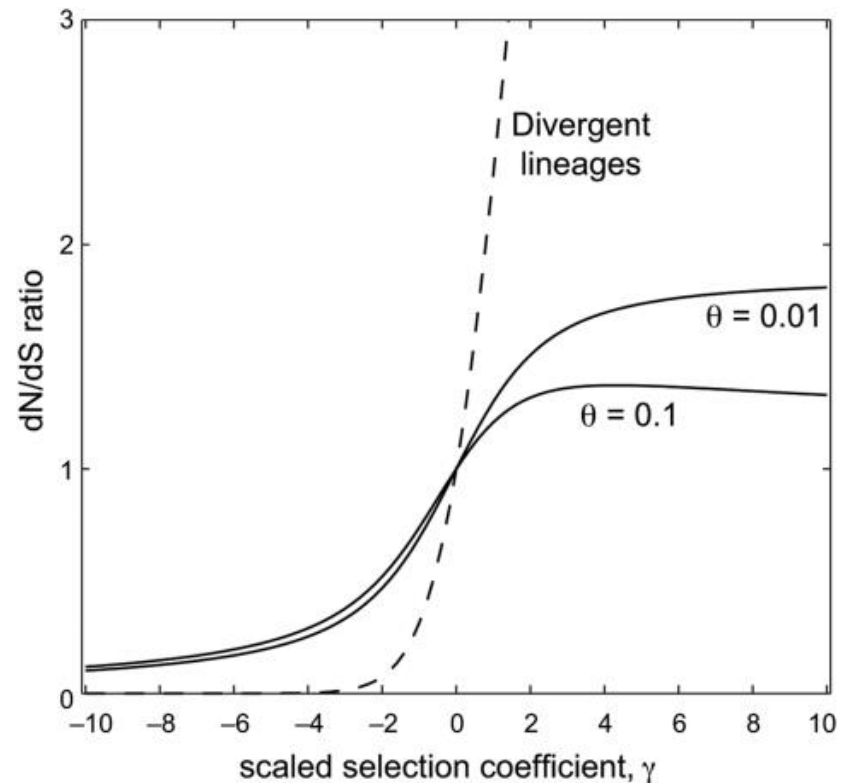

## 有害突变等位基因固定

突变等位基因固定概率:

$$u = \frac{1 - e^{-2s}}{1 - e^{-4Ns}}$$

小群体有利于有害突变等位基因的固定，降低自然选择功效，改变群落种间 $K_a/K_s$ 正/负选择的比率

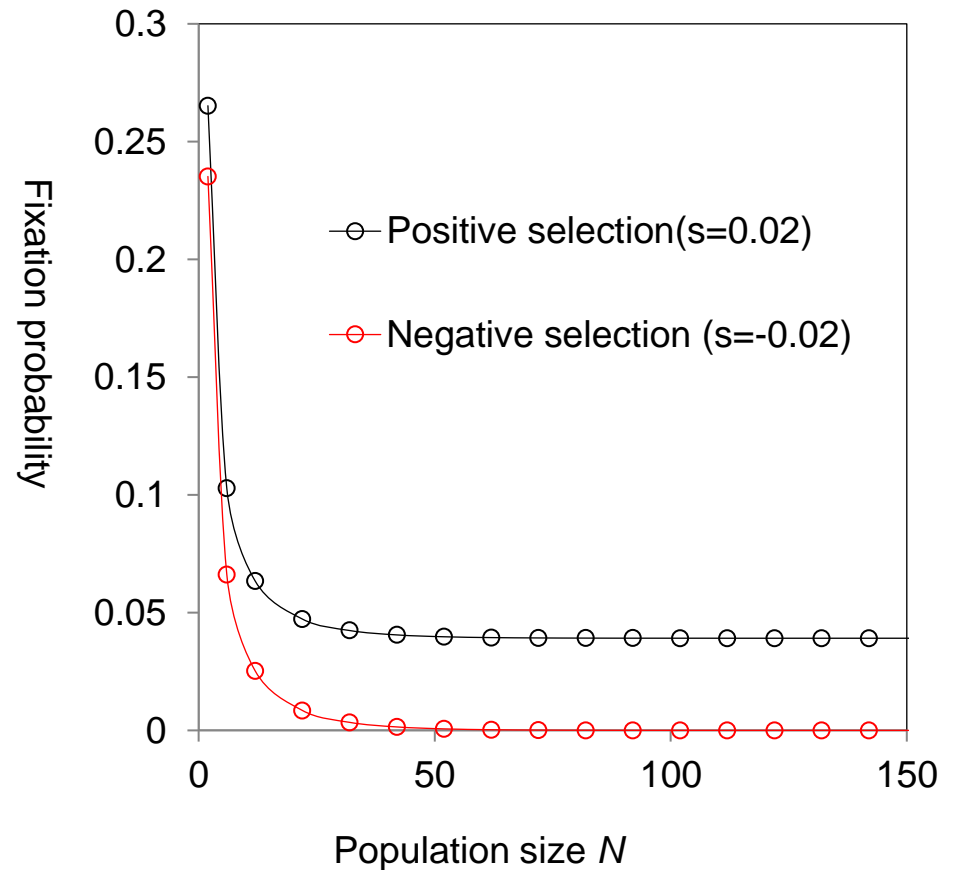

相同的基因在大小群落中种间 $K_a/K_s$ 正/负选择的比率不同，反映群落间自然选择压不同

# 群落物种共存关系设计：单一物种

## 1. 单一种群内：某物种在大群落与小群落的Ka/Ks 比率比较

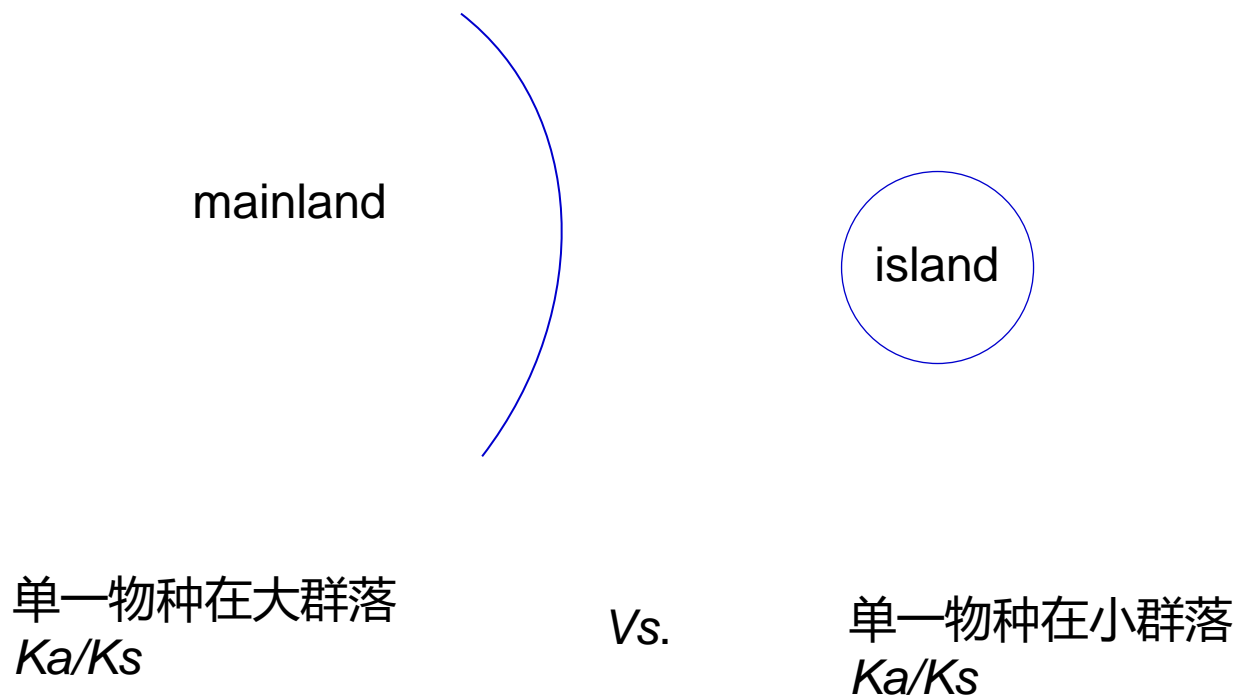

测验：单一物种在大小群落下的选择压变化

# 群落物种共存关系设计：成对物种

## Lotka-Volterra竞争模型的分子机制

$$\frac{dN_1}{dt} = r_1 N_1 \left( 1 - \frac{N_1}{K_1} - \alpha \frac{N_2}{K_2} \right)$$
$$\frac{dN_2}{dt} = r_2 N_2 \left( 1 - \beta \frac{N_1}{K_1} - \frac{N_2}{K_2} \right)$$

问题：(1) 怎样筛选成对共存物种？(e. g.,  $LD = P(AB) - P(A)P(B)$ )  
(2) 同一群落内或不同群落间的种内竞争  $Ka/Ks$  与 种间竞争  $Ka/Ks$ ?

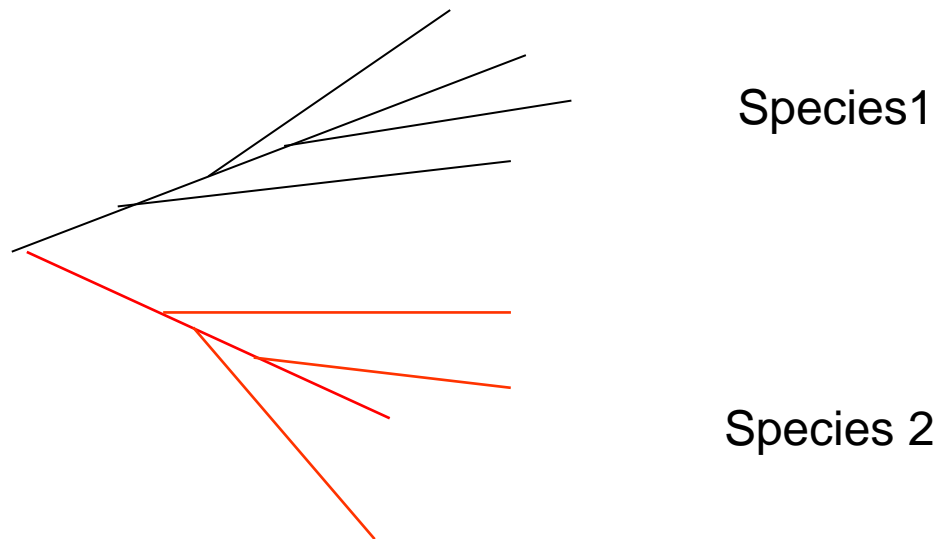

## 群落物种共存关系设计： 部分物种谱系

假如群落主要有下列物种，我们关注前面三物种，可设为前景支，其余物种位背景支，采用分支-位点模型(branch-site model)检测比对Ka/Ks以及选择压

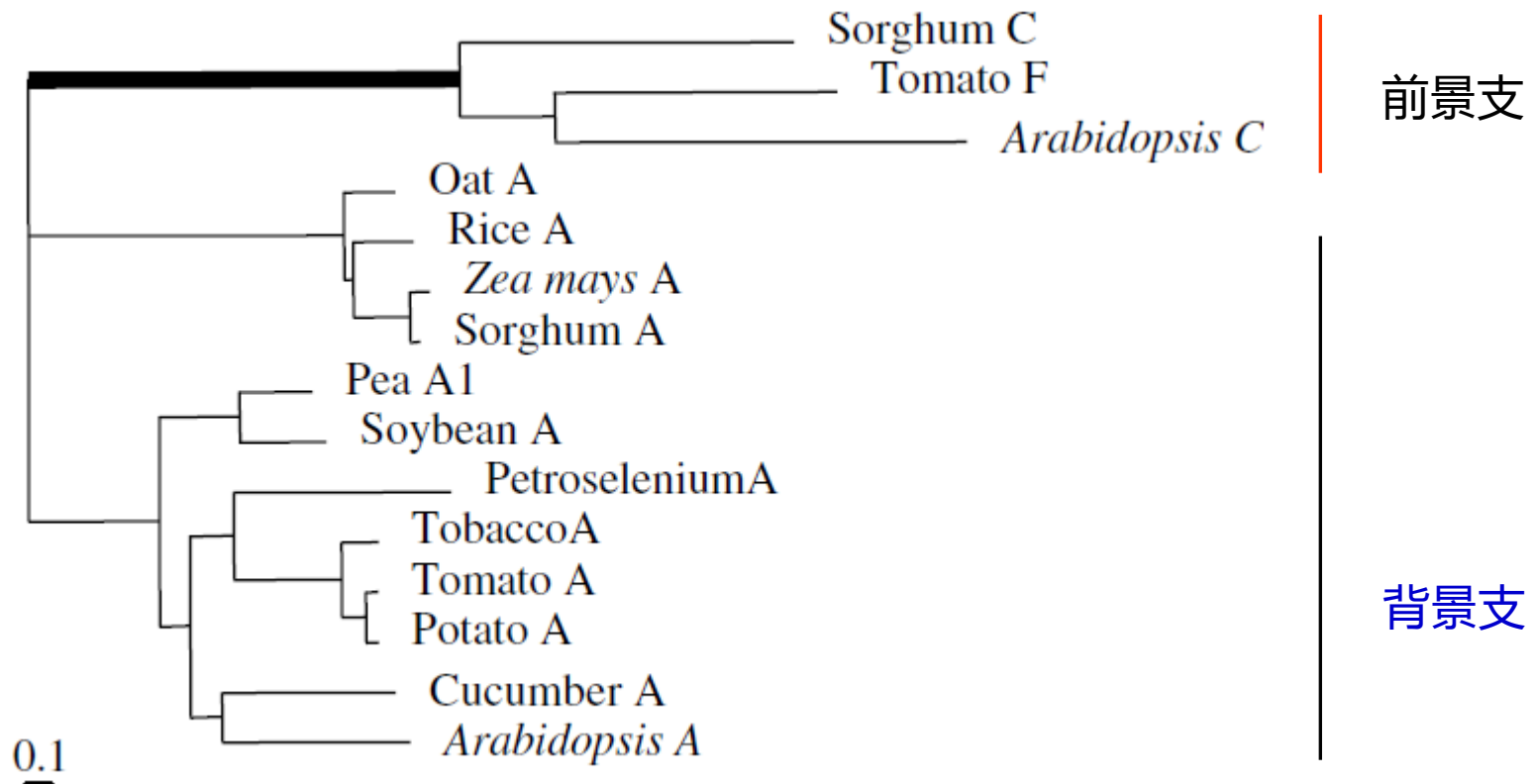

## 群落物种共存关系设计： 主要群落物种

主要群落物种  $Ka/Ks$  在不同群落选择压比较



以上分析的前提是应用筛选到种间同源性的功能表达基因

## 群落物种共存关系：分析步骤

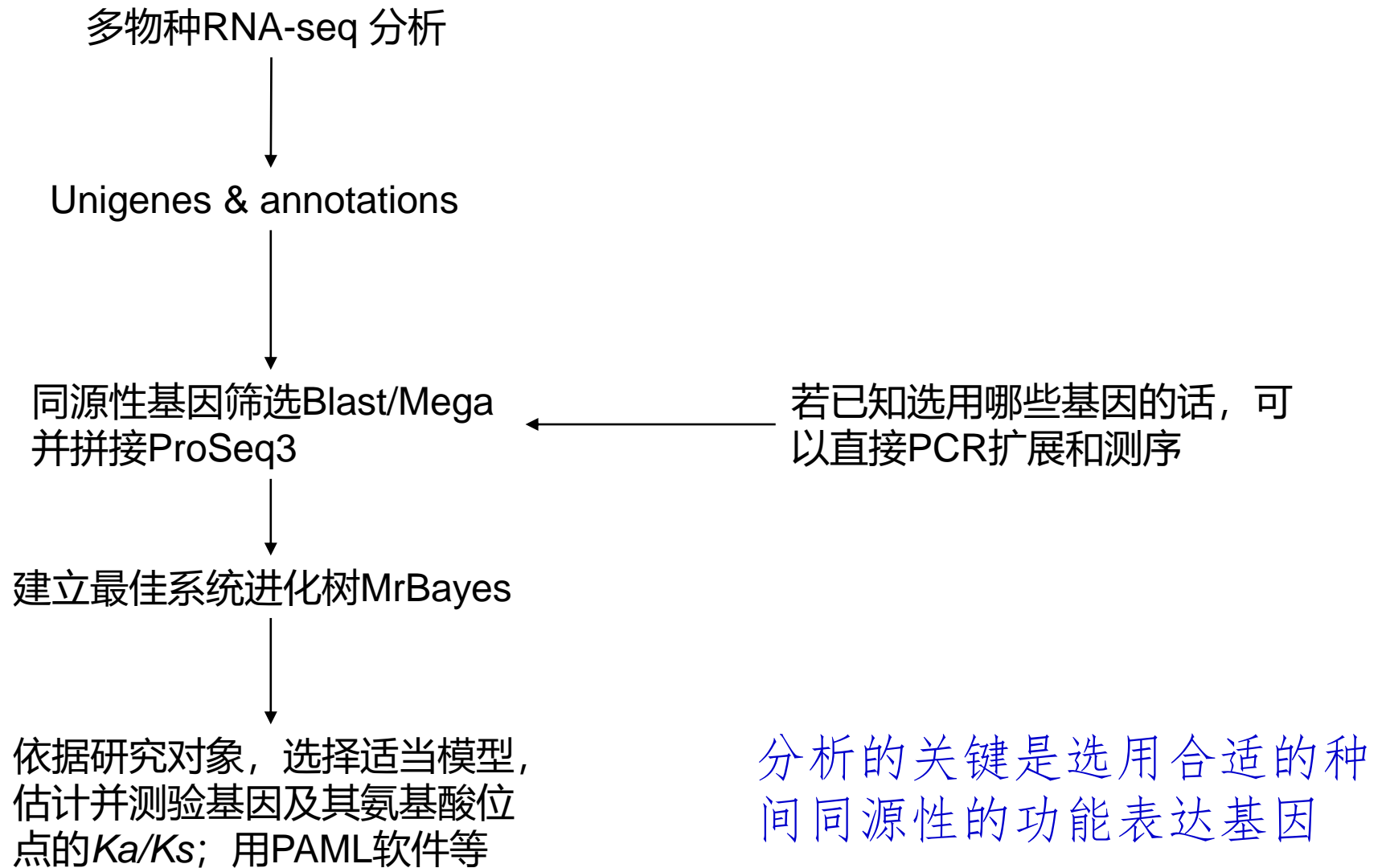



# 群落物种共存关系：用PAML测验 $Ka/Ks$

分支模型：应用LRT检验两种模型差异是否显著

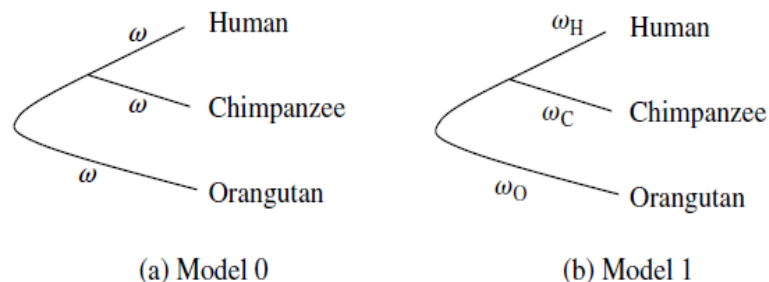

位点模型：

M2a/M1a

M3/M0

M8/M7

**Table 8.2** Parameters in models of variable  $\omega$  ratios among sites

Model	$p$	Parameters
M0 (one ratio)	1	$\omega$
M1a (neutral)	2	$p_0$ ( $p_1 = 1 - p_0$ ), $\omega_0 < 1, \omega_1 = 1$
M2a (selection)	4	$p_0, p_1$ ( $p_2 = 1 - p_0 - p_1$ ), $\omega_0 < 1, \omega_1 = 1, \omega_2 > 1$
M3 (discrete)	5	$p_0, p_1$ ( $p_2 = 1 - p_0 - p_1$ ) $\omega_0, \omega_1, \omega_2$
M7 (beta)	2	$p, q$
M8 (beta& $\omega$ )	4	$p_0$ ( $p_1 = 1 - p_0$ ), $p, q, \omega_s > 1$

$p$  is the number of parameters in the  $\omega$  distribution.

# 群落物种共存关系：用PAML测验 $Ka/Ks$

**Table 8.3** Log likelihood values and parameter estimates under models of variable  $\omega$  ratios among sites for 192 MHC alleles

Model	$p$	$\ell$	Estimates of parameters	Positively selected sites
M0 (one-ratio)	1	-8225.15	0.612	None
M1a (neutral)	2	-7490.99	$\hat{p}_0 = 0.830$ , ( $\hat{p}_1 = 0.170$ ), $\hat{\omega}_0 = 0.041$ , ( $\omega_1 = 1$ )	Not allowed
M2a (selection)	4	-7231.15	$\hat{p}_0 = 0.776$ , $\hat{p}_1 = 0.140$ ( $\hat{p}_2 = 0.084$ ) $\hat{\omega}_0 = 0.058$ ( $\omega_1 = 1$ ), $\hat{\omega}_2 = 5.389$	<b>9F 24A 45M 62G 63E 67V</b> <b>70H 71S 77D 80T 81L</b> <b>82R 94T 95V 97R 99Y</b> <b>113Y 114H 116Y 151H</b> <b>152V 156L 163T 167W</b>
M7 (beta)	2	-7498.97	$\hat{p} = 0.103$ , $\hat{q} = 0.354$	Not allowed
M8 (beta& $\omega$ )	4	-7238.01	$\hat{p}_0 = 0.915$ ( $\hat{p}_1 = 0.085$ ), $\hat{p} = 0.167$ , $\hat{q} = 0.717$ , $\hat{\omega}_s = 5.079$	<b>9F 24A 45M 63E 67V 69A</b> <b>70H 71S 77D 80T 81L</b> <b>82R 94T 95V 97R 99Y</b> <b>113Y 114H 116Y 151H</b> <b>152V 156L 163T 167W</b>

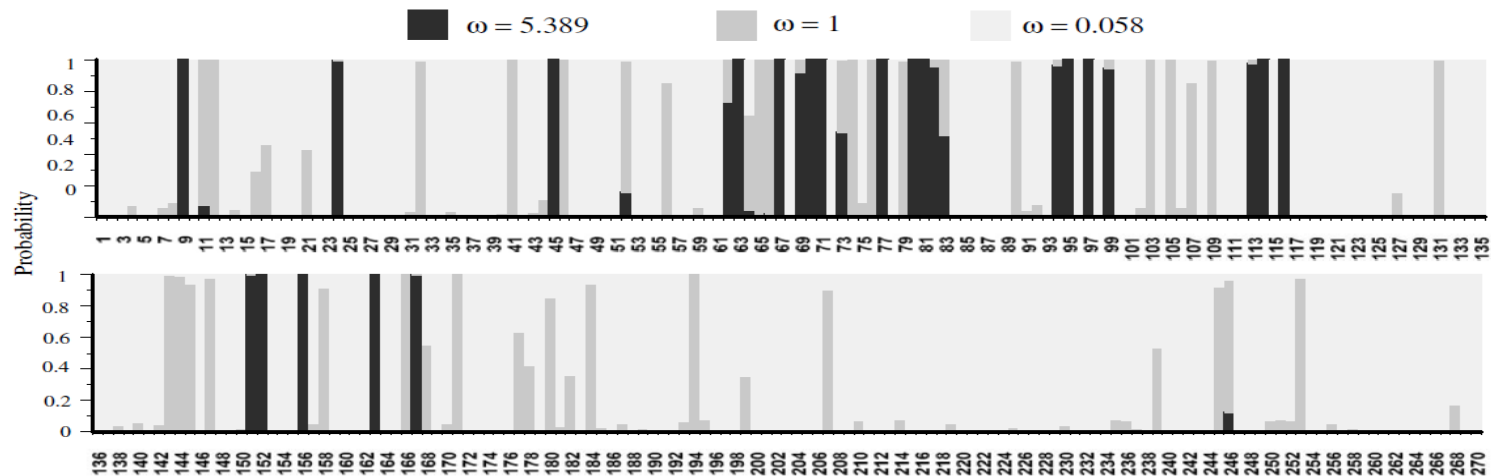

# 群落物种共存关系：用PAML测验 $Ka/Ks$

## 分支-位点模型

**Table 8.4** The  $\omega$  ratios assumed in branch-site model A

Site class	Proportion	Background $\omega$	Foreground $\omega$
0	$p_0$	$0 < \omega_0 < 1$	$0 < \omega_0 < 1$
1	$p_1$	$\omega_1 = 1$	$\omega_1 = 1$
2a	$(1 - p_0 - p_1)p_0 / (p_0 + p_1)$	$0 < \omega_0 < 1$	$\omega_2 > 1$
2b	$(1 - p_0 - p_1)p_1 / (p_0 + p_1)$	$\omega_1 = 1$	$\omega_2 > 1$

The model involves four parameters:  $p_0, p_1, \omega_0, \omega_2$ .

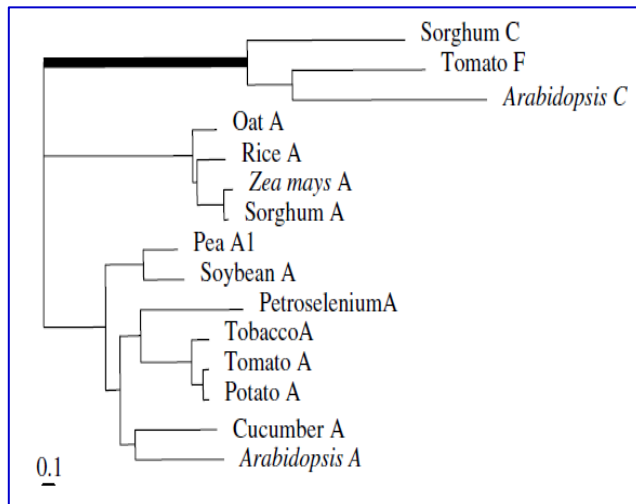

**Table 8.6** Log likelihood values and parameter estimates under various models for the phytochrome gene *phy* AC&F subfamilies

Model	$p$	$\ell$	Estimates of parameters
(a) One-ratio (M0)	1	-29 984.12	$\hat{\omega} = 0.089$
(b) Branch model (2-ratios)	2	-29 983.48	$\hat{\omega}_0 = 0.090, \hat{\omega}_1 = 0.016$
(c) Branch-site model A, with $\omega_2 = 1$ fixed	3	-29 704.74	$\hat{p}_0 = 0.774,$ $\hat{p}_1 = 0.073 (\hat{p}_2 + \hat{p}_3 = 0.153),$ $\hat{\omega}_0 = 0.078, \omega_1 = \omega_2 = 1$
(d) Branch-site model A, with $\omega_2 > 1$	4	-29 694.80	$\hat{p}_0 = 0.813,$ $\hat{p}_1 = 0.075 (\hat{p}_2 + \hat{p}_3 = 0.111),$ $\hat{\omega}_0 = 0.080, \hat{\omega}_2 = 131.1$

# 示例：石竹科 *Schiedea* 属27个岛屿物种 Vs. 大陆物种

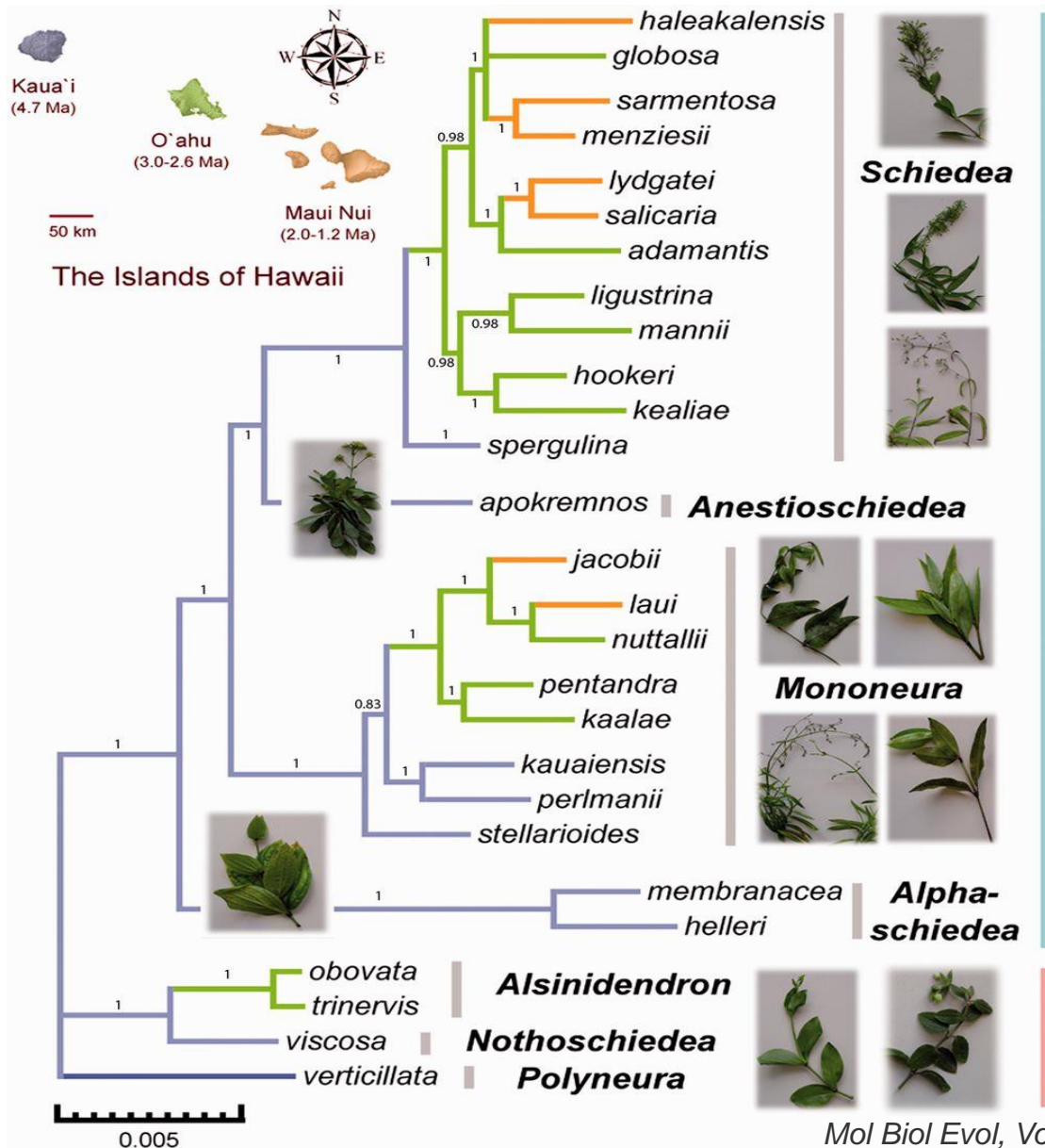

Unrooted tree of 27 *Schiedea* species representing perennial herbs, vines, and shrubs occurring in a range of contrasting environments. The phylogeny was estimated using a concatenated alignment of 36 nuclear genes using MrBayes (Ronquist and Huelsenbeck 2003)

## 案例: *Schiedea* 属27个岛屿物种 Vs. 大陆物种

---

比对的大陆(mainland)物种:

Asteraceae(菊科): 22 species

Fabaceae(豆科): 21 species

Poaceae(禾本科): 28 species

Tribe Cichorieae(菊苣族), *Helianthus*(向日葵), *Solanum*(龙葵): 6-8 species

*Citrus*(柑橘), *Populus*(杨树): 6-8 species

Number of genes: 11-21 genes

5 datasets of 6-8 近缘种进行了比较 ( tribe Cichorieae, *Helianthus*, *Solanum*, genera *Citrus*, *Populus* )

# 案例: *Schiedea* 属27个岛屿物种 Vs. 大陆物种

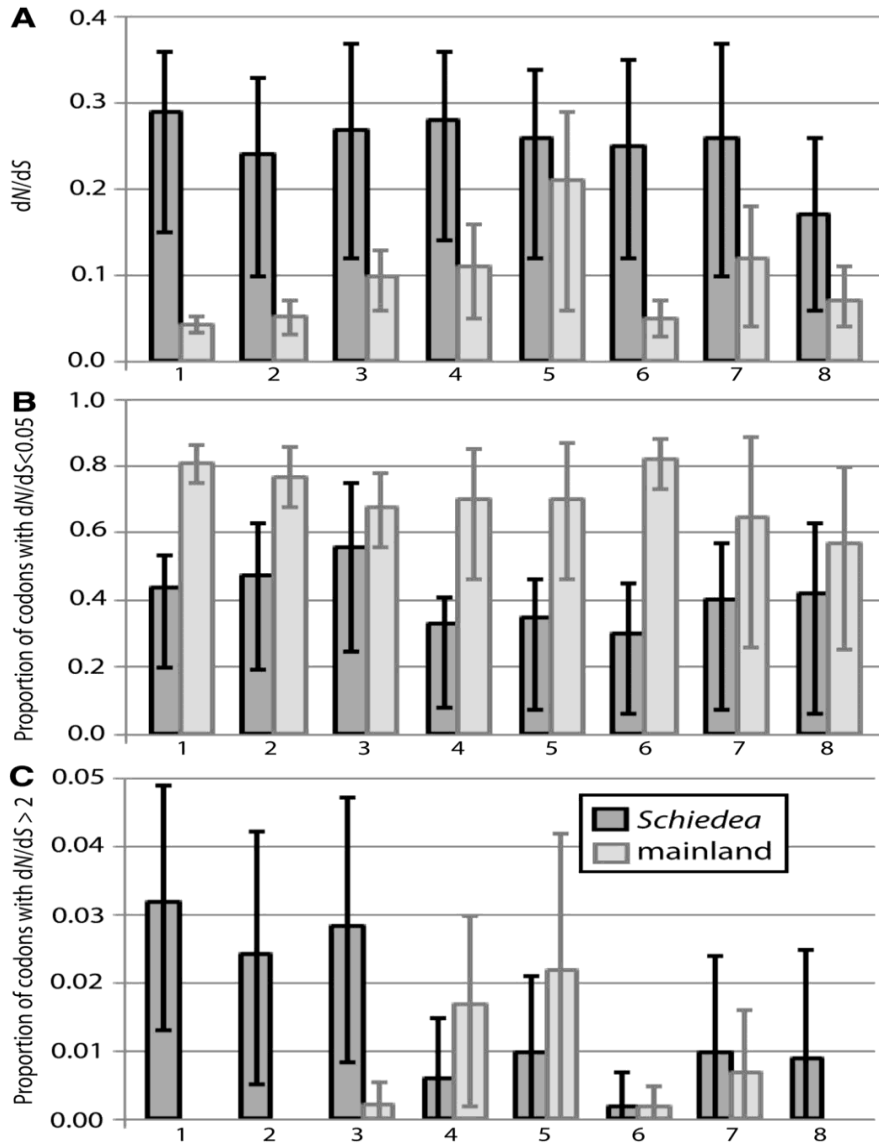

左边前三列分别与Poaceae, Asteraceae 及Fabaceae比较 (20 species) ;

其余5个与Helianthus, Populus, Cichorieae, Citrus, 及 Solanum(6-8 species) 比对

结果:

1. 岛屿物种的Ka/Ks要高于大陆物种的Ka/Ks;
2. 岛屿物种纯化选择压降低了; 正选择要比大陆物种更加普遍, 这个可能与该岛屿物种快速形成许多新物种有关, 有利于适应不同环境。

## 群落物种共存关系分子机制预测： 迁移的影响

### 上述案例：

群落J变小

→ 物种  $N_e$  变小，与选择  $s$  交互作用

→ 小群落减弱负选择  $Ka/Ks$  上升 ↑

### 迁移影响：

$m$ 与选择 $s$ 交互作用

→ 减弱正选择功效，维持负选择

→ 降低群落正选择 $Ka/Ks$ 的比率↓

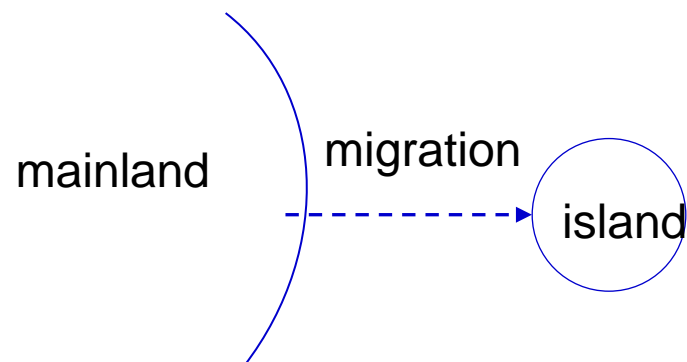

# 群落物种共存关系分子机制预测：交配系统影响

优势基因扩散速度：

Fisher(1937):

$$\frac{\partial p}{\partial t} = k \frac{\partial^2 p}{\partial x^2} + mpq, \quad \text{speed } c = 2(km)^{1/2}$$

Zhang et al. (2020; *Heredity*):

$$c_\alpha = \left( 2 \left( s_d + s_h + (s_d - s_h) \frac{\alpha}{2 - \alpha} \right) \left( \sigma_S^2 + \frac{1 - \alpha}{2} \sigma_P^2 \right) \right)^{1/2}$$

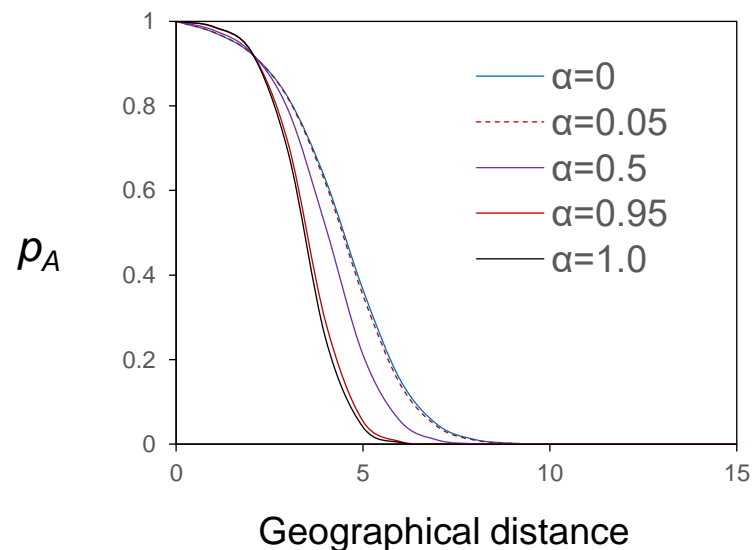
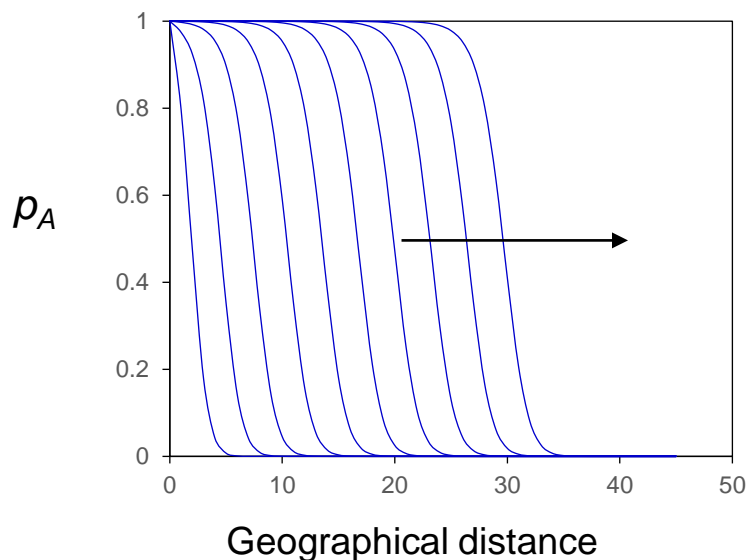



### Baker's law (1955)

通过长距离迁移而在岛屿上建立起来的物种，多数具有自交亲和性，因为自交亲和性物种在占领新生境有优势，不受有限的异源花粉源限制

物理上隔离的“岛屿”群落常常包含许多自交或近交物种

→ 减小有效群体大小  $N_e$

→ 增强有害基因的固定概率，降低自然选择压

→ 提高群落共存物种的负选择  $K_a/K_s$  的比率

谢谢~

欢迎讨论问题.....